

**CX400 SERIES
DUAL SETPOINT
SOLID STATE TIMER/COUNTER**

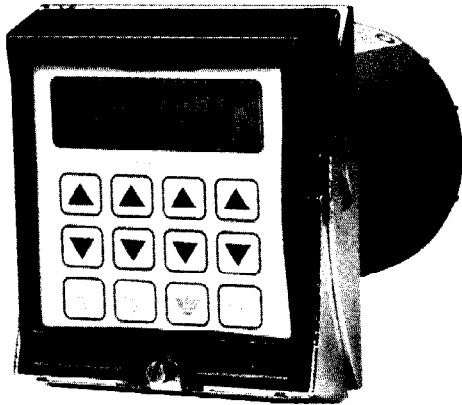

SPECIFICATIONS

Time/Count Range

SYM.	MAXIMUM RANGE	MINIMUM SETTING	COUNT RATE
1	19999 Cts	1 Count	7500/Sec 12-50 VDC Count Input
2	19999 Cts	1 Count	500/Min AC or DC
3	19999 Cts	1 Count	5000/Min AC or DC
4	199.99 Sec	.01 Sec	
5	1999.9 Sec	.1 Sec	
6	19.999 Sec	0.001 Sec	
7	199 Min:59 Sec	1 Sec	
8	199 Hr:59 Min	1 Min	

Time Inhibit/Count Line Terminals B & C

SYMBOL	VOLTAGE & FREQUENCY
CX411/CX441	12-50 VDC or 20-28 VAC, 50/60 Hz
CX412/CX442	120 VAC, 50/60 Hz or 120 VDC

Setting Accuracy

Count - 100%
Time - $\pm 0.1\%$ or 50ms, whichever is larger (0° to 60°C)

Repeat Accuracy

Count - 100%
Time - $\pm 0.1\%$ or 35ms, whichever is larger (0° to 60°C)

Rcset Time

30 ms following removal of voltage from terminal 1.

Operating Temperature

+32° to +140°F (0° to 60°C)

Operating Voltage/Frequency

SYMBOL	VOLTAGE & FREQUENCY
AG	120 VAC 50/60 Hz

Output Rating

Relay Contacts
 Instantaneous - 10 Amp (resistive) 120 VAC
 Delayed - 5 Amp (resistive) @ 120 VAC, 60 Hz
 Early Trip - 5 Amp (resistive) @ 120 VAC, 60 Hz
Mechanical Life - In excess of 20 million operations
Electrical Life - contingent upon contact load
Solid State - 1 amp, 0-264 VAC, VDC

Power On Response Time

300 ms maximum after voltage applied to terminal 11.

Battery Life

Lithium battery with an expected life of 10 years.

Laboratory Testing

U.L. Recognition E96337
C.S.A. Certified LR28861



**6
ELECTRONIC
TIMERS**

The CX400 is a microprocessor based, dual setpoint, timer/counter housed in a standard 15 terminal CYCL-FLEX® plug-in case which allows easy removal for programming changes and replacement.

Time or count operation, time range, and the type of start input switch operation are programmed with 7 miniature rocker switches located inside the unit housing.

The front panel of the CX400 is a sealed membrane keypad which provides excellent protection for most industrial environments. The time or count setpoint is entered using the increment and decrement keys for each digit position. The SET and ENT keys provide access to the setpoint, as well as to the front panel programmable software functions. These programmable functions control the pulse output length, setpoint to zero/zero to setpoint cycle progress indication, and count input scale factor. The software programming functions are indicated with abbreviated English word prompts to help the user program these functions without the need for written instructions.

A keypad lock function available in the software of the unit allows the setpoint to be viewed, but does not allow unauthorized changes.

Time and count cycle progress is shown on a 4-1/2 digit (19999) liquid crystal display. The digits are .5 inches high, and annunciators at the right hand side of the display indicate the operating mode. These annunciators flash to indicate when the unit is timing or counting.

Five time ranges are available from 19.999 seconds to 199 hours: 59 minutes. Three count input rate speeds can be programmed with the count display indicating a maximum of 19999. The count input scale factor can be used to extend the effective count range.

The CX400 is designed for 120 VAC operation. The count input is available for 120 volt AC or low voltage AC/DC operation. The count input circuit serves as a time inhibit (without resetting the unit) when the CX400 is programmed as a timer.

BULLETIN 188

OUTPUT OPERATION

The CX400 timer/counter has three relay outputs; 10 ampere instantaneous contacts, 5 ampere SPDT contacts that can be programmed for different output sequences, and 5 ampere SPDT contacts that are energized at a programmable cycle point prior to completion of the time/count cycle.

The instantaneous contacts are energized when power is applied to the start circuit. The instantaneous contacts remain energized until the unit is reset.

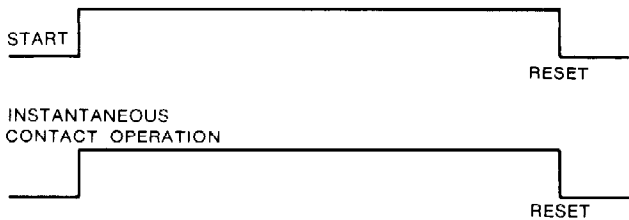

One set of the programmable output contacts can be programmed to provide a number of different output functions. These contacts are programmed using the first two rocker switches as described in the **PROGRAMMING PROCEDURE**. The output sequences available are:

OOX ON DELAY OPERATION — The contacts are energized at the end of the timing/counting cycle and remain energized until the unit is reset.

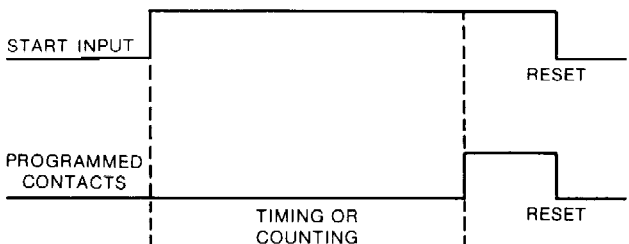

OXO INTERVAL OPERATION — The contacts are energized during the timing/counting cycle and then shut off at the end of the cycle.

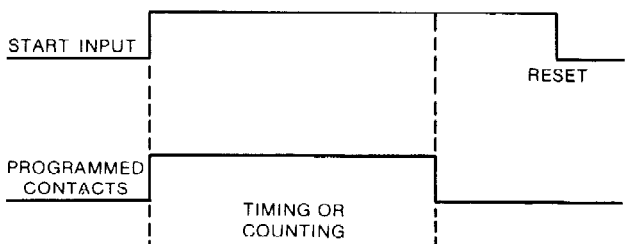

OOX PULSE OUTPUT OPERATION — The contacts are energized at the end of the timing/counting cycle for a pulse which is user programmable. See the **Front Panel Feature Programming** instructions for details on how to program the pulse length.

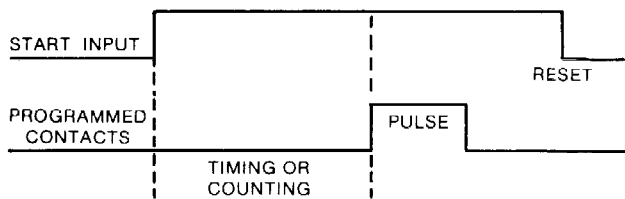

OOX PULSE AND REPEAT OPERATION — The contacts are energized at the end of the timing/counting cycle for a pulse which is user programmable. At the same time that the cycle is completed and the pulse output begins, the timing/counting cycle resets and begins again. This repeat operation continues as long as the start circuit is energized.

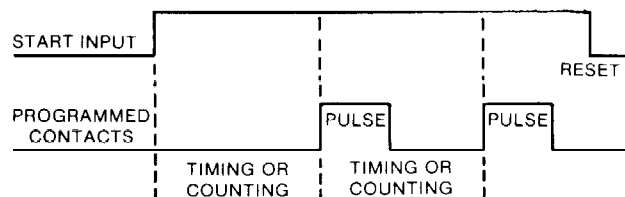

A second set of output contacts acts as an "Early Trip" output. These contacts can be programmed to energize at a point before the unit completes the timing or counting cycle, and remain energized until the unit is reset. This *early trip* setpoint is completely independent of the main cycle setpoint or any changes made to the main cycle setpoint. The following examples show how the *early trip* contacts work in relation to the programmed main cycle contacts. Examples are shown for both the ON DELAY (OOX) and INTERVAL (OXO) modes. The timing or counting time line indicates the main cycle setpoint for the unit.

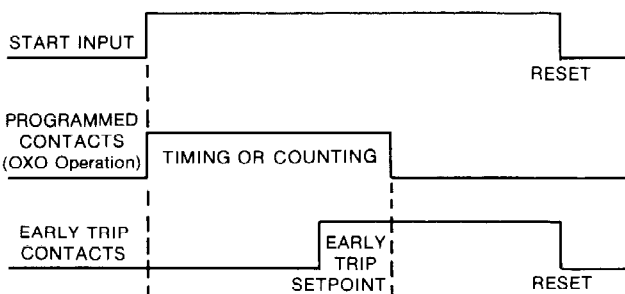
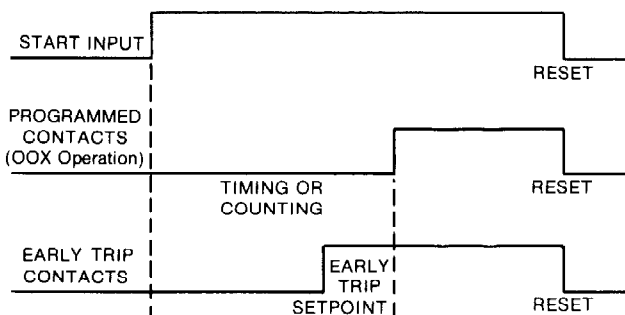

A solid state version of the CX400 is also available with two normally open MOSFET circuits used as the programmable output and the early trip output as shown in the above timing diagrams. The MOSFET circuits will switch 1 ampere continuous load from 0-240 VAC or VDC. The MOSFET circuits have a very low leakage current when OFF. Refer to the wiring diagrams for terminal assignments for all outputs.

START MODE INPUTS

There are two start modes for the unit. In the standard start mode, POWER is applied to terminal 1 to START the timing or counting cycle. The unit will reset if power is interrupted to terminal 1.

In the reverse start mode, POWER is applied to terminal 1 to RESET the unit. The timing or counting cycle begins when power is disconnected from terminal 1. (Terminal 11 provides the power to operate the unit in this mode.)

In the reverse start mode the unit will retain its actual cycle progress value if power is interrupted. If it is desired that the unit continue its cycle instead of resetting if there is a power failure the reverse start mode must be used.

The unit can be used with either a sustained start input or a momentary contact input. When a momentary contact input is used with the standard start mode, an OXO interval output on the unit must be used to provide power back to the start input on terminal 1. See the wiring diagrams for more information.

TIME INHIBIT/COUNT INPUT

The CX400 has two terminals (B & C) which act as either a count input when the unit is programmed as a counter or as a time inhibit input when the unit is programmed as a timer. The B-C terminals operate on either 120 volts AC or DC (CX412/442) or low voltage AC or DC (CX411/441).

Application of voltage to the B-C inputs will result in a count being registered in the counter mode. See the programming procedure section for more information on how the count modes operate.

In the timer modes, the application of voltage to the B-C inputs will stop the timing cycle and hold the outputs in their last state without resetting the unit. Timing will continue and the outputs will be allowed to change according to their programmed operating modes when voltage is removed from terminals B-C.

PROGRAMMING PROCEDURE

A series of 7 miniature rocker switches located inside the unit housing are used to program the time/count range and the load sequence of the CX400 Timer/Counter. The following table defines the switch conditions to program the operating parameters. **CAUTION: The product label should always be marked to indicate the operating mode of the unit.**

X = Switch ON O = Switch OFF Blank = Does Not Apply

SYM.	PROGRAMMED CONTACTS OUTPUT SEQUENCE	SWITCH NUMBER							Notes
		1	2	3	4	5	6	7	
1	OOX — ON DELAY	X	X						
2	OXO — INTERVAL	O	X						
3	OO <input checked="" type="checkbox"/> Pulse Output	X	O						a
4	OO <input checked="" type="checkbox"/> Pulse & Repeat	O	O						a, b
TIME OR COUNT INPUT RANGE									
1	COUNT—7500/Sec			X	X	X			b, c
2	COUNT—500/Min			O	X	X			d
3	COUNT—5000/Min			X	O	X			d
4	TIME .01 Sec			O	O	X			
5	TIME—0.1 Sec			X	X	O			
6	TIME—0.001 Sec			O	X	O			
7	TIME—Min/Sec			X	O	O			e
8	TIME—Hrs/Min			O	O	O			e
BATTERY									
1	Battery ON						X		f
2	Battery OFF						O		f
START MODE									
1	Standard Start						O		
2	Reverse Start						X		g

NOTES:

- a. In reverse start operation, if a power interruption occurs during the pulse output, the unit will power up in the pulse output mode and complete the time remaining for the pulse output.
- b. When programmed for range 1, load sequence 4 (pulse and repeat), the maximum count rate is 2500/second.
- c. When programmed for count range 1, counts are registered upon application (leading edge) of voltage to the count line. **USE RANGE #1 WITH 12-50 VDC COUNT INPUT (CX411).** In addition, count input line length must be considered and not exceed 50 feet of twisted pair, shielded cable. Shield must be attached to earth ground or machine frame at machine frame end of cable.
- d. When programmed for count range 2 or 3, counts are registered when voltage is removed (trailing edge) from count line. Range 2 should be used whenever possible to provide the best protection from contact bounce of the count source.
- e. In these ranges the last two digit positions are limited to 59. If a setpoint exists in memory from another range where the last two positions can be greater than 59, a new setpoint must be entered if the unit is reprogrammed to range 7 or 8.
- f. Battery must be switched off for storage or shipment. Battery must be switched on for proper operation of CX400 unit.
- g. In the reverse start mode if power is interrupted the accumulated time which has elapsed, but not resulted in a change in the display is lost. For example, a timer is set for the hour:minute range with one minute remaining to time out shown on the display, but only 10 seconds actual remaining to time out. If a power interruption occurs, the unit will power back up with the last full minute remaining before time out.

Entering and Displaying Setpoints

When the CX400 unit is powered up for the first time, or after the battery has been cycled off and on, the digit display will show four hyphens. The unit will not operate until it has been provided with a setpoint, clearing the display of hyphens.

To create or change the main setpoint, press the **SET1** key. The setpoint, if any, is displayed and the panel key pads become active. The operation of the timing or counting function and the output loads are not affected. For setpoint changes, the SET indicator appears on the graphics panel. The setpoint is changed by pressing appropriate Δ or ∇ key pads. Pressing a Δ key increments the setpoint digit located above the key; the ∇ key decrements the digit located above the key. If the key is continually depressed the digit will change every .5 second until the key is released. The display will carry to the digit on the left on the 9 to 0 transitions when using the Δ keys. The display will borrow from the digits on the left on the 0 to 9 transitions when using the ∇ keys. On ranges 7 and 8, the display will carry on the 59 to 00 transition and borrow on the 00 to 59 transition of the two least significant digits.

When the desired setpoint is displayed, touch the **ENT** key. The new setpoint is entered, all Δ and ∇ keys become inoperable and "SET" disappears from the graphics panel. New setpoints can be entered while the unit is timing or counting, but they will not take effect until the next reset.

To create or change the *early trip* setpoint press the **SET2** key. The *early trip* setpoint is changed by pressing the Δ or ∇ keys as noted above. When the desired setpoint is displayed, press the **ENT** key.

The setpoints may be displayed at any time without disturbing the timing or counting cycle by pressing **SET1** or **SET2**. The actual value is returned by pressing **ENT**.

NOTE: If the main setpoint is set to zero, the programmed contacts are always ON if programmed for any of the OOX modes, and always OFF if programmed for OXO.

Front Panel Feature Programming

In addition to the setpoint, the SET and ENT keys are used to access the front panel programmed software functions. These functions are the pulse output length, the direction of the cycle progress indication, and the count input scale factor. After the **SET1** key is pressed the first time, and the setpoint is displayed, the **SET1** key can be pressed and held for about 5 seconds to call the front panel programming routine. A series of prompts will appear to indicate that the program variables can be entered. The **SET1** key is pressed repeatedly to scroll through the programming sequence. **The ENT key is used to enter any changes made to the variables into memory. If the ENT key is not pressed after a change is made, the change will not be entered into memory.**

The prompts which appear are as follows:

PULS Indicates that the value which will appear after the next actuation of the SET key will be the pulse output length setpoint.

CYCL Indicates that the direction of the cycle progress display can be selected.

SCAL Indicates that the value which will appear after the next actuation of the SET key will be the count input scale value.

The CYCL prompt will appear no matter what time or count operating mode has been selected. However, the PULS prompt will only appear if the unit has been programmed for either the pulse or pulse and repeat cycle modes. The SCAL prompt will only appear if the unit has been programmed as a counter.

Note that the default values for these programmed functions are for a 00.10 second pulse, cycle progress down from the setpoint to zero, and a count scale factor of 1. These default values will occur without any programming. These default values are also the same as those found on previous CX series.

Programming The Pulse Output Length

The delay contacts on the CX400 can be set to energize for a period of time and then shut off by using either the single pulse output mode (output sequence 3) or the pulse and repeat mode (output sequence 4). The length of the output pulse can be set from .01 to 199.99 seconds as follows.

To program the pulse output length, press the **SET1** key the first time so that the setpoint is displayed, and the SET annunciator appears at the right of the LCD display. Press and hold the **SET1** key again for about 5 seconds, and the PULS prompt will appear.



The appearance of the PULS prompt indicates that the unit is ready to accept programming for the pulse length. Press the **SET1** key again, and the display will show the default value 00.10 seconds (100 milliseconds). The increment and decrement keys can now be used to set a pulse output length to any value up to 199.99 seconds. When the desired pulse length setpoint is displayed the value is entered into memory by pressing the ENT key. When the ENT key is pressed the display will flash indicating that the setpoint has been entered. Note that the display will continue to display the pulse setpoint value so that further adjustments can be made if required.

When the correct pulse output duration is programmed, press the **SET1** key once to scroll to the next programming prompt or press and hold the SET key to return to the main setpoint. When the main setpoint is displayed, press the ENT key to display the actual time/count value.

Application Notes:

1. If the pulse output is programmed for a length of time greater than the overall time or count cycle time for the unit, the pulse output will stay on continuously.
2. If the pulse output length is programmed for 00.00, the output will not come on.
3. The pulse output length cannot be programmed when used with the combination of the 7500/second count range (count range 1) and the pulse and repeat output mode (output mode 4). With this operating mode combination, the pulse output is fixed at 00.10 seconds, and cannot be changed.
4. In the reverse start mode the actual value of the pulse output is retained in case of power failure. When power is reapplied to the unit the pulse output will turn back on and complete the remaining part of its cycle.

Programming The Cycle Progress Direction

The CX400 can be programmed to show the actual time or count progress proceeding either down from the setpoint to zero or up from zero to the setpoint. Either up or down cycle progress indication is available in any time or count mode. The cycle progress indication can be changed in the middle of a cycle.

To program the cycle progress direction, press the **SET1** key the first time so that the main setpoint is displayed and the SET annunciator appears at the right of the LCD display. Press the **SET1** key again until the CYCL prompt appears.



The appearance of the CYCL prompt indicates that the unit is ready to accept programming for the cycle progress direction. Press the **SET1** key again and the display will show either the "dn" prompt indicating that the unit will show cycle progress proceeding from the setpoint down to zero or the "UP" prompt indicating that the display will show cycle progress proceeding up from zero to the setpoint. The down cycle progress direction is the default. Use the increment and decrement keys to select the desired direction. When the desired cycle progress direction is displayed, press the ENT key to enter the choice into memory.



Press the **SET1** key once again to move to the next programming prompt, or press and hold the SET key until the display returns to the main setpoint. When the main setpoint is displayed, press the ENT key to display the actual time/count value.

Programming The Count Input Scale Factor

When programmed as a counter, the CX400 count input can be scaled for a factor between 1 and 255 through front panel programming. The number of incoming count pulses will be divided by a user selected scale factor between 1 and 255. The display will show, and the actual output operation will be based on the number of count input pulses received divided by the scale factor value. This allows the unit to display and control counting in engineering units such as gallons. This also allows the unit to count over 5,000,000 pulses (19999 x 255) with a 19999 display value.

To program the scale factor, press and hold the **SET1** key until the SCAL prompt appears.



The appearance of the SCAL prompt indicates that the unit is ready to accept programming of the scale factor value. Press the **SET1** key again, and the display will show 0001, indicating that a scale factor of 1 (the default value) is entered. The scale factor can be changed using the increment and decrement keys. Note that the scale factor can only be set in the range of 1 to 255. The unit is programmed to disregard any attempts to program a scale factor outside of this range.

When the desired scale factor is displayed, press the ENT key to enter this value into memory. The display will flash to indicate that the new scale factor has been entered.

Press the **SET1** key again to return to the main setpoint and leave the prompted programming routine. When the main setpoint is displayed, press the ENT key to display the actual time/count value.

A typical use of the scale factor might be in a flow control application. As an example, consider an application in which a paddlewheel flowmeter in a one inch pipe has a K factor of 144 pulses per gallon of flow. For this particular example, it is desired that the control turn the flow on for 100 gallons, then shut the flow off. The CX400 is programmed as a counter and the pump and valve control is connected to an interval (OXO) output. The scale factor is set at 144. When the CX400 receives count pulses from the flow meter, it will count 144 pulses before the display registers one count (one gallon).

The setpoint of the CX400 is programmed for 100, indicating that the unit will turn the flow on for 100 gallons. When the cycle is started, the CX400 will turn the flow on and then shut it off after it has counted 14400 pulses (100 gallons) from the flow meter.

$$\frac{14400 \text{ count input pulses}}{144 \text{ counts per gallon scale factor}} = \text{setpoint of 100 gallons}$$

Note that while the CX400 could be programmed to simply count 14400 pulses using the 19999 display, the use of the scale factor allows the programming of the display in the easier to understand engineering unit.

NOTE: In reverse start operation the actual displayed count value, and the scaled count pulses which have not yet resulted in a count being registered are retained in memory in case of power failure.

Keypad Lock

A keypad "lock" is provided on the CX400 Timer/Counter to prevent unauthorized tampering. To initiate the keypad lock, press the Eagle Signal logo key for 5 seconds. To disable the lock to change setpoints, remove power from the unit and turn the battery off and then on. The unit will lose all setpoints and they must be re-entered for further operation.

WIRING DIAGRAMS — CX411/CX412
Bold Lines are Internal Wiring

Power to unit is applied to terminals 11 and 2. The unit is started by applying power to terminals 1 and 2. Note that power should be applied to terminal 11 at least 300 msec before power is applied to terminal 1. An isolated input is provided on terminals C and B which functions as a count input when the unit is used as a counter, or as a time inhibit input when the unit is programmed to operate as a timer. Two sets of instantaneous contacts are provided which transfer whenever terminal 1 is energized. In addition, two sets of programmable contacts are provided. When programmed for Reverse Start, the unit will start when voltage is removed from terminal 1.

TIMER — SUSTAINED START INPUT

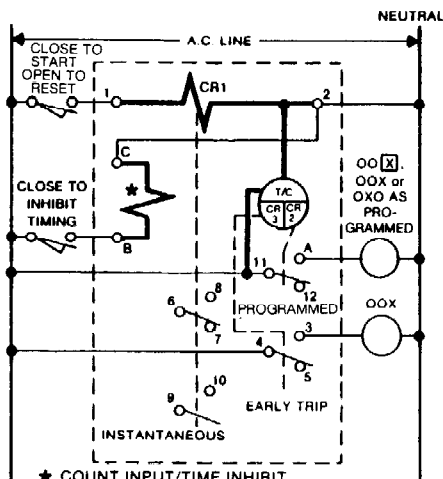

* COUNT INPUT/TIME INHIBIT.
CX411 MODEL NOT AT SERVICE VOLTAGE LEVEL. REFER TO SPECIFICATIONS.

Standard Start — Close start switch to time; open to reset. Unit resets on power failure. Set point is maintained by battery. Instantaneous contacts actuate with start switch. Delay contacts actuate as interval (OXO), delay (OOX) or delay, pulse output OO ☒ sequence as programmed. Early trip contacts actuate at the programmed setpoint prior to time out.

TIMER — SUSTAINED START INPUT REVERSE START

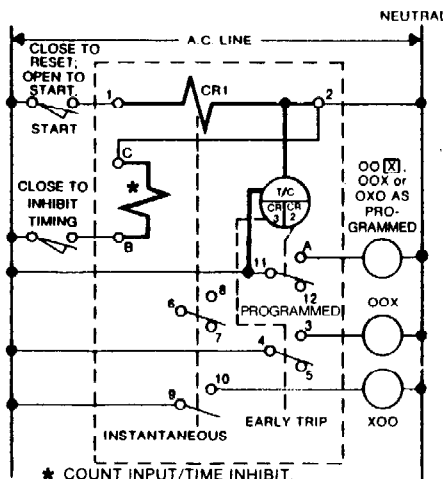

* COUNT INPUT/TIME INHIBIT.
CX411 MODEL NOT AT SERVICE VOLTAGE LEVEL. REFER TO SPECIFICATIONS.

Reverse Start — Open switch to start; close to reset. Unit does not reset on power failure. Closing inhibit switch will stop cycle progress without resetting unit. Battery retains cycle progress and setpoint on power failure. Cycle continues when power is restored.

TIMER — MOMENTARY START INPUT

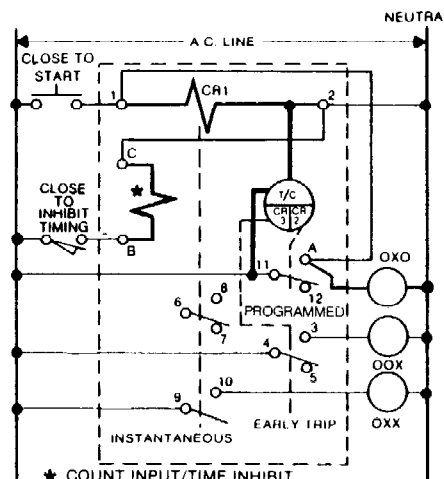

* COUNT INPUT/TIME INHIBIT.
CX411 MODEL NOT AT SERVICE VOLTAGE LEVEL. REFER TO SPECIFICATIONS.

Momentary Start — Close start switch to time; automatic reset at end of timing period whether start switch is open or closed. Programmed contacts must be programmed for OOX output. Note the jumper between A and 1 to provide "lock in" power to the start circuit.

WIRING DIAGRAMS — Relay Output — CX411/CX412
Bold Lines are Internal Wiring

CX412A6
A.C. COUNT INPUT
SUSTAINED START INPUT

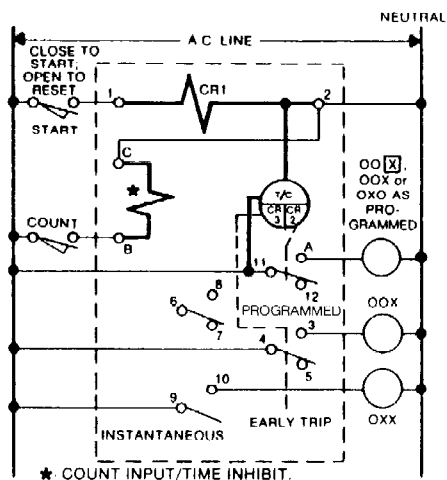

CX412A6
A.C. COUNT INPUT
SUSTAINED START INPUT
REVERSE START

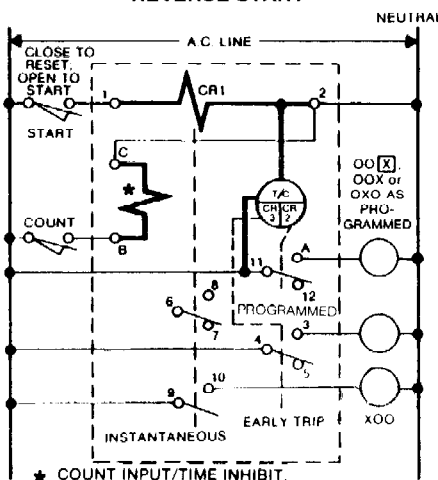

CX411A6
D.C. COUNT INPUT
MOMENTARY START INPUT

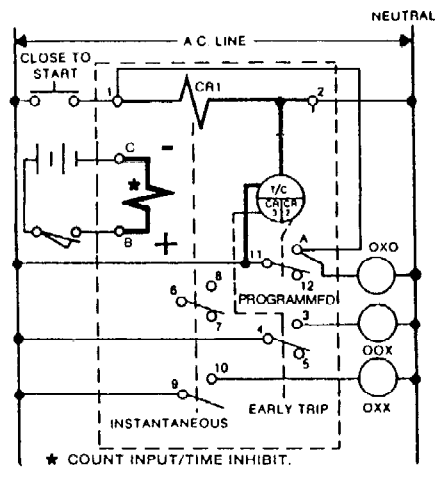

Standard Start — Close start switch to start, open to reset. Counts are registered when count switch opens. Unit resets on power failure, setpoint is maintained.

Reverse Start — Close start line switch to reset, open to start. Counts are registered when count switch opens. Unit does not reset on power failure. Battery retains cycle progress and setpoint.

Momentary Start - Close to start Automatic reset at end of counting period whether start switch is open or closed. Programmed contacts must be programmed for OXO output. Note the jumper between A and 1 to provide "lock in" power to the start circuit.

WIRING DIAGRAMS — Solid State Output — CX441/CX442
Bold Lines are Internal Wiring

CX442A6
TIMER - SUSTAINED START INPUT

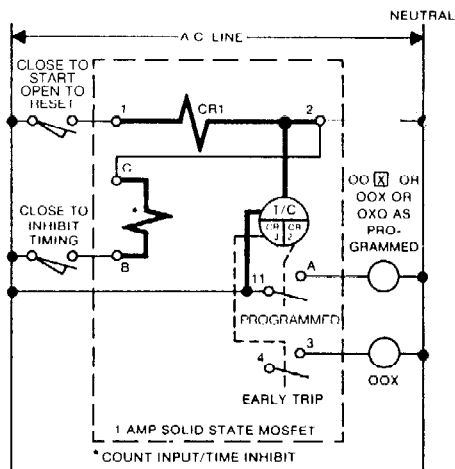

CX441A6
D.C. COUNT
MOMENTARY START INPUT

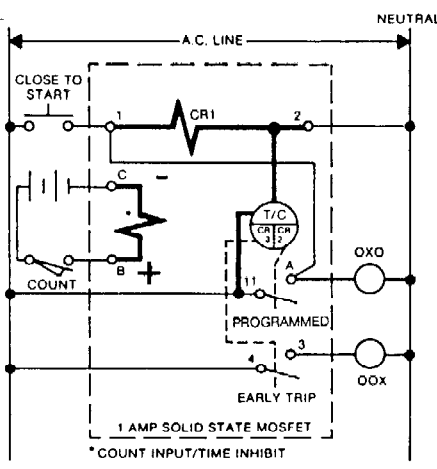

Standard Start — Close start switch to time; open to reset. Cycle progress is stopped without reset by closing inhibit switch. Unit resets on power failure. Setpoint is maintained by battery. Solid state delay contact actuates as interval (OXO) or delay (OOX) sequence as programmed by rocker switches.

Momentary Start — Close switch to start. Automatic reset at end of cycle with start switch open or closed. (Programmed for OXO output ONLY.) CX441 count/inhibit wiring shown.

If the CX400 count input is switched by a solid state device which has an off state leakage current in excess of those specified in the following table, a resistor must be attached across terminals B and C as shown in the illustration.

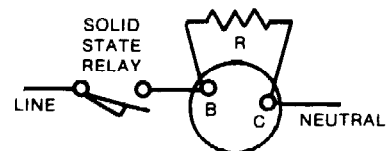

R = 9K 3W
 Eagle Signal P/N PCR-1418

Input Turn-On Current	MIN TYP MAX		
	DC	2.0 ma	2.5 ma
AC	1.4 ma	1.8 ma	2.2 ma

Input Turn-On Current With Resistor Attached	MIN TYP MAX		
	DC	4.8 ma	6.1 ma
AC	3.4 ma	4.3 ma	5.3 ma

CX WIRING AND INSTALLATION PROCEDURES

1. Install the resistor capacitor suppressor, Eagle part number PBN2002 between terminals 2 and 11. A PBN2002 resistor capacitor suppressor (Quencharc) kit is shipped with every CX.
2. After wiring is complete, power should be applied constantly to terminal 11. The CX should be started and reset by closing and opening switch to Terminal 1 only. This meets the requirements of having power to terminal 11 at least 300 milliseconds before power is applied to terminal 1.
3. In electrically noisy environments, it may be necessary to suppress the loads. Most commonly, electrical noise can be traced to the inductive loads in the control circuit. It is especially important to quench inductive loads turned ON and OFF by the CX. A quencharc (Part Number PBN2002) should be placed in parallel with the load. This should be done at the load but can be done by wiring a quencharc between terminal 2 and the switching contact.
4. The CX should be well grounded to the enclosure and the enclosure should be on a good factory ground. The CX's housing lower mounting hole is used as a ground connection. (See Mounting Dimension section in this bulletin.)
5. Do not bundle AC wires. Do not bundle input wiring lines to terminal 1, 11, and 2 with relay output wiring. Do not bundle AC wires with DC input wires.
6. Any large components such as motor starter contactors that emit EMI should be located a couple of feet away from the CX.

ENCLOSURES

PART NUMBER	NEMA CLASS	DESCRIPTION
HN308	1	Surface Mtg. with terminal block
HN364	1	Surface Mtg. without terminal block
HN370	1A	Dual unit cabinet less unit cases and toggle switch, with 9 terminal block.

ACCESSORIES

PART NUMBER	DESCRIPTION
H-5331	Mounting Brackets 2 req'd per timer
HP50-31	One Hole Mounting Ring
HP50-131	CYCL-FLEX Water - Sealed Housing Provides NEMA 4 Hosedown rating for CX Series Timer/Counters
HP50-133	Surface Mounting Adapter to use in place of Brackets
PDM-534	1/4 DIN Adapter Plate

MOUNTING DIMENSIONS

XX = INCHES
(XX) = MILLIMETERS

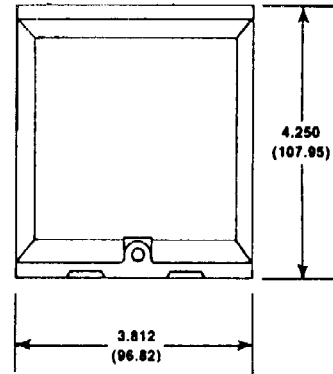
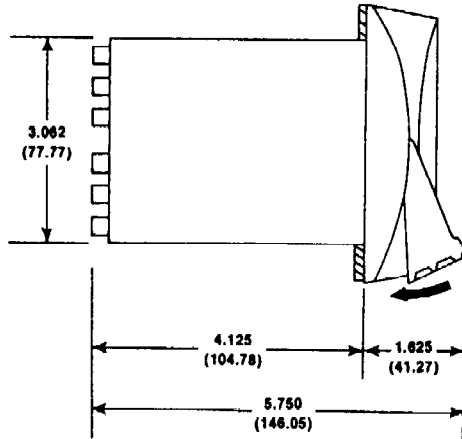
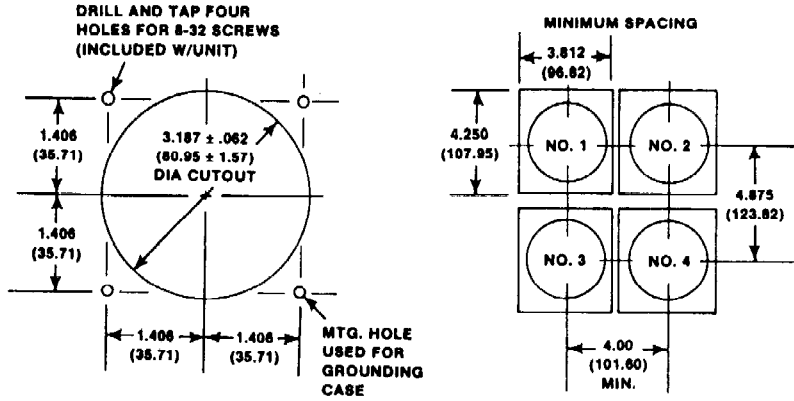

6
ELECTRONIC
TIMERS

ORDERING INFORMATION

